



moduline



INTERNATIONAL
HOSPITALITY
EXHIBITION

13-17
OTTOBRE
2023

fieramilano



3 YEAR WARRANTY C&H / Holding Line

Series HHA

Ventilated Holding Trolleys

New Line - Hot holding trolleys with AIRFLOW + system

Moduline Airflow+ is the new line of Ventilated Hot trolleys.

Features

Stainless steel structure and chamber and external panel.

*External glossy plexiglass with rounded edges and the possibility to wrap images or client logo and 2 long side handles. *(optional)

Internal Air Distribution Conveyor to ensure temperature uniformity into the chamber. Hot Box drawer system with water tank to add moisture during holding cycles.

Humidity management trough 2 door vents.

* WI-FI Connected -Wifi functions with Android APP or Web App to set, control and download data. *optional.

Available in Hot Holding version or Neutral Transport version.

Available capacity: 10 x GN 1/1
10 x GN 2/1 - 20 x GN 1/1
20 x GN 1/1
20 x GN 2/1 - 40 x GN2/1



3 YEAR WARRANTY C&H / Holding Line

HSH - HSW - HHT with WI-FI option

Holding



Wifi connection with plexiglass control panel.

New optional

Features:

All models are made in Stainless steel, with black plexiglass control panel and **DELI WARM** heating system **+30/120°C**

AISI 304 Chamber with rounded edges, double humidity vent on the door.

All doors and drawers are insulated, with gasket and magnetic closing.

Security thermostat placed on control panel.

WI-FI Connected

WI-FI CONNECTED: only available on single temperature/ chamber models. HSW - HSH - HHT



HHF 112



HHF 153



New models with high capacity trolleys with Climachef, to have an accurate humidity control, water tank on the side, touch screen control to set and save different process.

Multilevel function to keep under control the holding time of different kind of food.

Features

Realised with a strong stainless steel structure.

High capacity, Climachef humidity control, Multilevel, Core probe able to hold food at exact temperature at the core.

Integrated water tank, HCCP data, Touch screen control.

Glazed door with lights.

Available capacity: 16xGN2/1 - 32GN1/1
(8 multi level zones)

10xGN2/1 - 20GN1/1
(5 multi level zones)



XXS

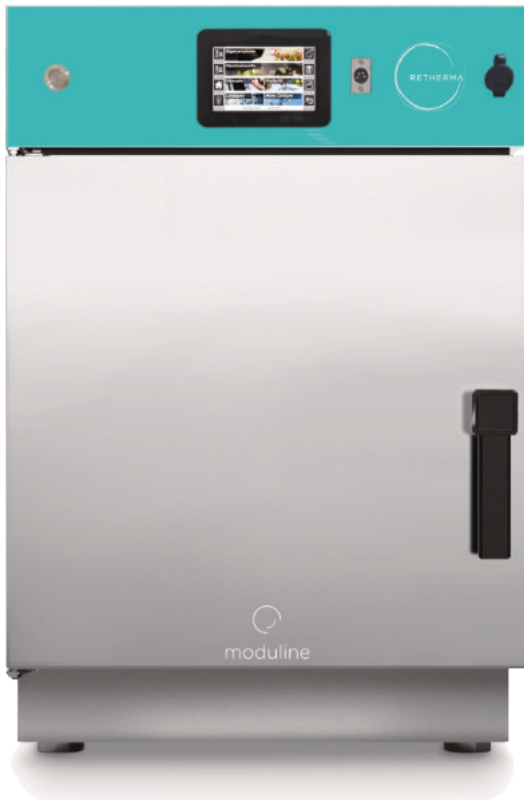

New TOUCH SCREEN - with new Great Functions

XXS series is an extremely Compact Regen Oven.

Just 55cm width and 56cm depth* can be installed into a standard domestic furniture. (* measured form chamber frame to the back panel)

The New capacitive touch screen is user friendly, easy to use but with a lots of new functions.

Also the power is changed, the new Retherma 6 and 10 trays have an increased **temperature range: 30°/ 210°C**

The **QR code function** allows to set all the regeneration process just reading a QR code or a Bar code, no skilled people are needed and all the process is under control.

Climachef, USB and core probe as standard (on GRE) gives a full control on regeneration cycles.

WI-FI CONNECTED

Water Drawer System as optional: Water fill and Waste water in one single optional. 4 L. Water capacity is a great feature when you don't have water connection available on site.

Water Drawer System as to be ordered with GRE model.



HHF Ventilated holding with CLIMA CHEF and MULTILEVEL

HHF112E 10 GN2/1 76mm 1000x855xh.1130mm +30/120°C 2,8kW 230V
20 GN1/1 **€ 6.200,00**

HHF153E 16 GN2/1 76mm 1000x855xh.1680mm +30/120°C 2,8kW 230V
32 GN1/1 **€ 8.200,00**



WI-FI OPTIONAL for holding range single temperature



Wi Fi optional available for all Moduline Holding Line
Not available for Multi-temperature / double chambers models

AMW

Remote cloud control system

€ 500,00

REThERMA New optionals, features and models.



New touch screen 5" version with new software and WI-FI connection **Available from JUNE 2024**

GRE060T XXS	6 GN2/3	64mm	550x560/590xh.822mm	+30/210°C	3,45kW	230V
						€ 5.100,00
Version with automatic washing system GRE060TW XXS						€ 5.700,00

New XXS VERSION AVAILABLE AS STANDARD ON 060 MODELS + OPTIONALS

NEW TEMPERATURE RANGE +30°C / 210°C on all Retherma models as standard. **Jan - 2024**

Optional



AOL XXS	Double Glazed door for Retherma 060 - 106 - 061	€ 350,00
----------------	---	-----------------

Special Optional for RETHERMA XXS



ASA - XXS	4l + 4l water	550x560/590xh.128mm	€ 1.200,00
------------------	---------------	---------------------	-------------------

Built-in water fill and wastewater drawers (no fixed water supply connection required)

New XXS GRE 060C/D/E and GCE 060 C/D/E/ with new compact dimension

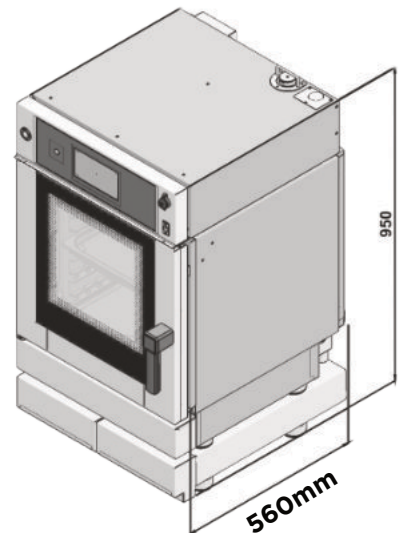
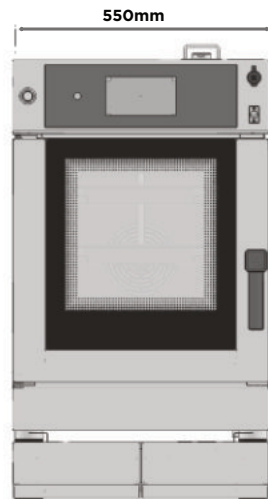

HHA Ventilated holding Line

HHA101EV	10 GN1/1	60mm	545x774xh.1156mm	+30/90°C	2,3kW	230V	€ 3.850,00
HHA101N	10 GN1/1	60mm	545x774xh.1156mm	N.A.	N.A.	N.A.	Neutral / transport Trolley € 2.860,00



HHA102EV	20 GN1/1	60mm	750x889xh.1156mm	+30/90°C	2,3kW	230V	€ 4.378,00
	10 GN2/1	60mm					
HHA102N	20 GN1/1	60mm	750x889xh.1156mm	N.A.	N.A.	N.A.	Neutral / transport Trolley € 3.445,00



HHA201EV	20 GN1/1	60mm	578x740xh.1857mm	+30/90°C	2,3kW	230V	€ 5.280,00
HHA201N	20 GN1/1	60mm	578x740xh.1857mm	N.A.	N.A.	N.A.	Neutral / transport Trolley € 3.718,00



HHA202EV	20 GN2/1	60mm	783x855xh.1857mm	+30/90°C	2,3kW	230V	€ 5.720,00
	40 GN1/1	60mm					
HHA202N	20 GN2/1	60mm	783x855xh.1857mm	N.A.	N.A.	N.A.	Neutral / transport Trolley € 4.167,00



HHA Optional BLACK finish



Black finish optional includes:

Glossy plexiglass external panels with rounded edges

Easy handling thanks to the low weight and long side handles.

Big side cable reel

ABK00X BLACK FINISH OPTIONAL € 500,00



AMW Remote cloud control system € 500,00

Different tray rack Options 75mm



APXHHA101 Removable tray rack 8GN1/1 pitch 75mm € 300 ,00

APXHHA201 Removable tray rack 16 GN1/1 pitch 75mm € 450 ,00

APXHHA102 Removable tray rack 8GN2/1 pitch 75mm € 400 ,00

APXHHA202 Removable tray rack 16 GN2/1 pitch 75mm € 600 ,00



PER001 Eutectic refrigeration tray GN1/1 € 160,00

NEW STANDS

ABA061H GCE/GRE 061/101 STAND suitable for drawers 800x760xh.920mm
 CSD-HSW 011 / 012 / 013 or CSC/HSB 052 **€ 702,00**



ABA031H CVE Stand suitable for drawers 750x760xh.935mm
 CSD-HSW 011 / 012 / 013 or CSC/HSB 052 **€ 702,00**



ABA106H GCE/GRE 060/106/110 STAND suitable for 550x710xh.900mm
 CSD-HSW 001 / 002 / 003 or CSD-HSB 031 / 051 **€ 640,00**



NEW OPTIONALS AND FEATURES

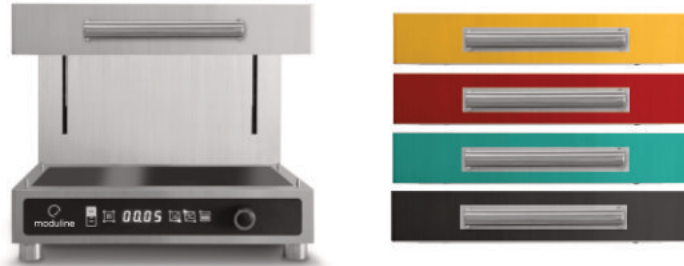

SEH-C RAL RAL PAINTING additional cover for Salamanders

Clients can require a RAL painting for an additional Cover which will be installed on the salamander cover.

€ 580,00

Customer can also require this additional component in SS and paint it by himself **SEH-C € 250,00**

New Features on touch screen combi steamer GCE-T



- Led lights on the frontal door
- 4 fan speed as standard
- Wifi Connection
- Model 060 became **060 XXS**
- Power button on the control panel at top left



moduline